



SUPERFEST

THE INTERNATIONAL DISABILITY FILM FESTIVAL

Sunday, November 2, 2014
11 AM–5:30 PM

Presented by



PAUL K. LONGMORE
Institute on
Disability



LightHouse for the
Blind and Visually Impaired

Hosted by

**CONTEMPORARY
JEWISH MUSEUM**

connecting art, people, and ideas

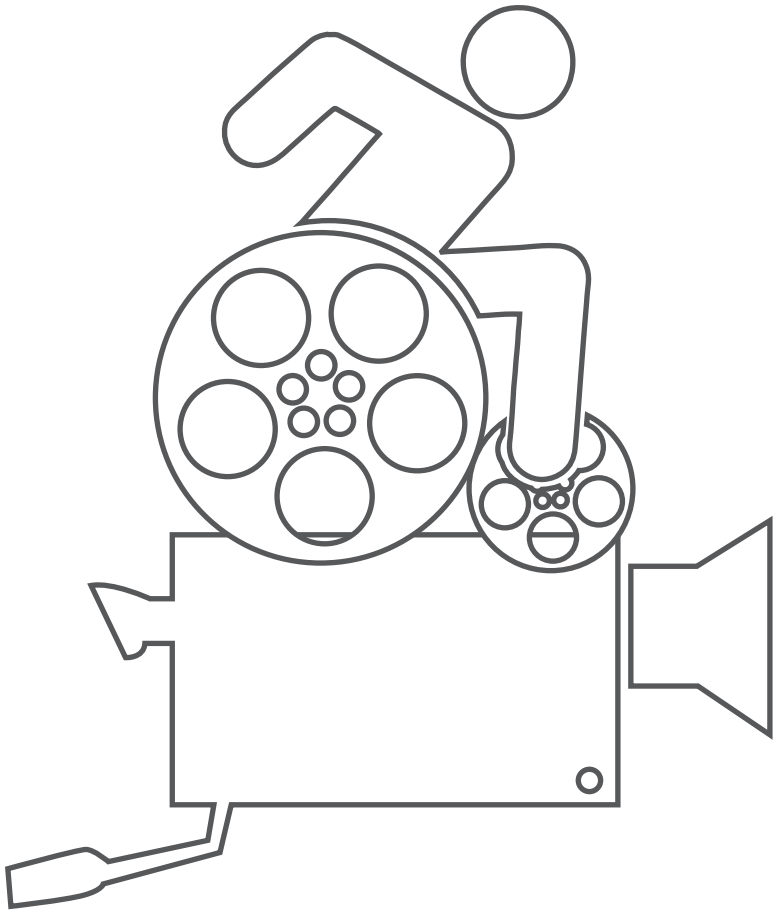

Superfest is the longest running festival of its kind. Founded in 1970, this yearly Bay Area grassroots event has grown into an international media showcase honoring the unique contributions of the expanding disability arts and culture movement, exhibiting the most innovative and provocative works from established and emerging filmmakers. People with disabilities inform every part of Superfest, as leaders, participants, and judges. We are proud of our local roots and commitment to building in multiple forms of access to encourage everyone to imagine movie-going in new ways.

The Paul K. Longmore Institute on Disability

The Longmore Institute at San Francisco State University works at the crossroads of disability history, the arts, education, and social justice. Through cultural programs, teaching, and outreach, we promote disability as a source of ingenuity and an engine of change. With Superfest, we are proud to celebrate people with disabilities by bringing together students, community members, and innovative filmmakers.

<http://longmoreinstitute.sfsu.edu>

LightHouse for the Blind

LightHouse for the Blind and Visually Impaired is a consumer and advocacy organization committed to advancing the rights of blind individuals. Founded in 1902, LightHouse is the most comprehensive organization serving Northern California's blind community. LightHouse is a strong representative for Superfest because of its rich history among Bay Area disability groups, and its established history of promoting the rights and interests of disabled people.

<http://lighthouse-sf.org>

Superfest Superstar Sponsor

Michelle Spitz,
Woman of Her Word



Silver Sponsors

Audio Eyes

Amramp

George Lucas Family Foundation

Golden Gate Regional Foundation

Guide Dogs for the Blind

Big Screen Sponsors

ABL Denim

City College of San Francisco, Disabled Students Programs and Services

Independent Living Resource Center of San Francisco

Whill

Venue Sponsor

The Contemporary Jewish Museum

Community Sponsors

Autism Social Connection at Community Gatepath
Community Group
Bay Area Outreach and Recreation
Blind Babies Foundation
Bridges to Communication
California Foundation for Independent Living Centers
CHADD of Northern California
Changing One Mind at a Time
CIL Berkeley
Cinema Studies, SFSU
Creative Growth Art Center
DCARA
Dept. of Rehabilitation, External Affairs
DeYoung Museum
Down Syndrome Connection of the Bay Area
DREDF
Environmental Traveling Companions
Independent Living Resource Center SF
Law Office of Lainey Feingold
Myers Urbatsch P.C.
National Alliance on Mental Illness
National Institute of Art and Disability
Parents Education Network
People with Disabilities Foundation
Seesaw Friends
Senior and Disability Action
Sins Invalid
Smith-Kettlewell Eye Research Institute
The Arc (SF)
Young Life Capernaum



Nina G.



Nina G., America's favorite (and only!) female stuttering stand-up comedian, is our emcee for today's festivities. Masterfully infusing humor into social justice issues, Nina helps shatter misconceptions through her quick wit and deft jokes.

Raised in the East Bay, Nina was diagnosed with a Learning Disability and began to stutter while in elementary school. She attended UC Berkeley, the hub of the Disability Rights Movement. She later received her doctoral degree and works toward access for people with disabilities. Nina strives not to overcome her disability but to overcome the limiting attitudes about what people with disabilities can achieve.



Schedule

Morning Session 11–2 PM

The Limbless Mountaineer (UK)

Directed by Paul Crompton, 2014

47 minutes

Paul Crompton documents quadruple amputee Jamie Andrew as the experienced mountaineer attempts to climb the Matterhorn.

The Mural (US)

Directed by Fran Guijarro, 2014

19 minutes

This documentary follows the collaboration of artists: people with developmental disabilities from the San Francisco ARC and civic artists from freespace.

Juggle and Cut (US)

Directed by Caleb Slain, 2013

14 minutes

A spinal cord injury has thrown into question Andy Phelps' passions of juggling, unicycle-riding, and fire-breathing. In this documentary, Phelps shares his new-found career as a film editor.

Shining Into (US)

Directed by Thanh Diep, 2004

2 minutes

Thanh Diep poetically asserts her self-worth while grappling with society's negative perception of her as a person with cerebral palsy.

Everything is Incredible (HN)

Director Tyler Bastian, Trevor Hill, & Tim Skousen
Merit Award, 2011

10 minutes

Using scraps found in his poor Honduran neighborhood, wheelchair rider Agustin has been working to build a homemade helicopter for over fifty years.

Filmmaker Q&A

Afternoon Session 2–5:30 PM

Vectors of Autism: A Documentary about Laura Nagle (US)

Director John Schaffer
Excellence Award, 2012

40 minutes

In this unusual? Lyrical? documentary, Laura Nagle draws viewers into her experiences of autism—from her struggles to live independently to her unique ways of thinking that fuel her career as an architect.

The Nature of Pleasure (US)

Directed by Thanh Diep, P.K., 2004
Walker Innovation in Craft Award

8 minutes

Local Bay Area artist Thanh Diep pushes the avant-garde in her second film of the festival, as she explores her relationship to love, sex, and disability.

Once Again (US)

Directed by J. Spottswood Moore

Excellence Award, 2014

19 minutes

Using a mixture of home video footage and original animation, Spottswood Moore vividly portrays what it is like to grow up with obsessive compulsive disorder.

Restraint and Seclusion: Hear Our Stories (US)

Directed by Dan Habib

Advocacy Award, 2013

28 minutes

A panel of people with disabilities discuss their experiences being restrained and secluded as students, uncovering the abuse occurring under the guise of “education” in American schools.

The Interviewer (AU)

Directed by Genevieve Clay-Smith & R. Bryan

Best of Festival Award, 2012

13 minutes

In this humorous short, when Thomas Howell goes to interview for his dream job at a prestigious law firm, his preconceptions about disabilities are challenged.

Krutch (US)

Directed by Clark Matthews

Disabled Filmmaker Award, 2013

6 minutes

[Film Content Warning: *The film “Krutch” contains explicit sexual content and nudity. Anyone who is under 18 will be asked to leave the room for the screening.]*

This sexy short follows a physically disabled woman as she unwinds after a long day.

Filmmaker Q&A

*Come join fellow disability movie-buffs at our after party at **Thirsty Bear (661 Howard Street)**, free admission to the venue, with drinks and food available for purchase.*

A Message from The Contemporary Jewish Museum

The Contemporary Jewish Museum (The CJM) is honored to host Superfest: The International Disability Film Festival. As a welcoming and engaging place where diverse audiences can connect with Jewish culture, history, art and ideas, The Museum strives to ensure that its facilities, exhibitions, and programs are accessible to all its visitors. We are committed to offering a variety of resources and programs for individuals of all abilities, and believe that everyone deserves equal access to the arts.

For more information about Access programs at The CJM, contact Cecile Puretz, Education & Access Manager: access@thecjm.org or 415.655.7856.

The CJM also plays a key leadership role the Bay Area Arts Access Collective (BAAAC)—a professional learning network that aims to empower the arts and cultural community in the Bay Area to become more accessible and inclusive of patrons with disabilities. To learn more about BAAAC’s mission and upcoming workshops: bayareaartsaccess@gmail.com or find us on FB.



Major support for Access Programs at The Contemporary Jewish Museum comes from Wells Fargo Foundation.



Additional Thanks

Previous Superfest Coordinator: Liane Yasumoto

Judges: Bryan Bashin, Regan Brashear, Edana Contreras, Anne Finger, Jennifer Justice, Catherine Kudlick, Mahalia LeClerc, Victor Santiago Pineda

Emcee: Nina G.

Superfest Committee: Bryan Bashin, Emily Smith Beitiks, Catherine Kudlick, Jennifer Sachs & Alex Wilson

Poster Designer: Dana Lui

Program Designer: Alexandra Soiseth

Special Thanks: Audio Eyes (and in particular Rick Boggs), The Contemporary Jewish Museum, Culture! Disability! Talent!, San Francisco State University College of Liberal & Creative Arts, San Francisco State University Disability Programs & Resource Center.

And last but not least, a special shout out to all of our generous and talented volunteers!

Support Superfest

Please make a difference and join our community of supporters. Make a tax deductible donation to Superfest today.

Donate online at <http://superfestfilm.com/sponsors> or call Jennifer Sachs at (415) 694-7333.